

THIS DRAWING IS UNPUBLISHED. RELEASED FOR PUBLICATION  
 © COPYRIGHT - BY TYCO ELECTRONICS CORPORATION. ALL RIGHTS RESERVED.

LOC	DIST	REVISIONS					
G	14	P	LTR	DESCRIPTION	DATE	DWN	APVD
		B		REV PER ECR 08-028314	18NOV08	JR	TM

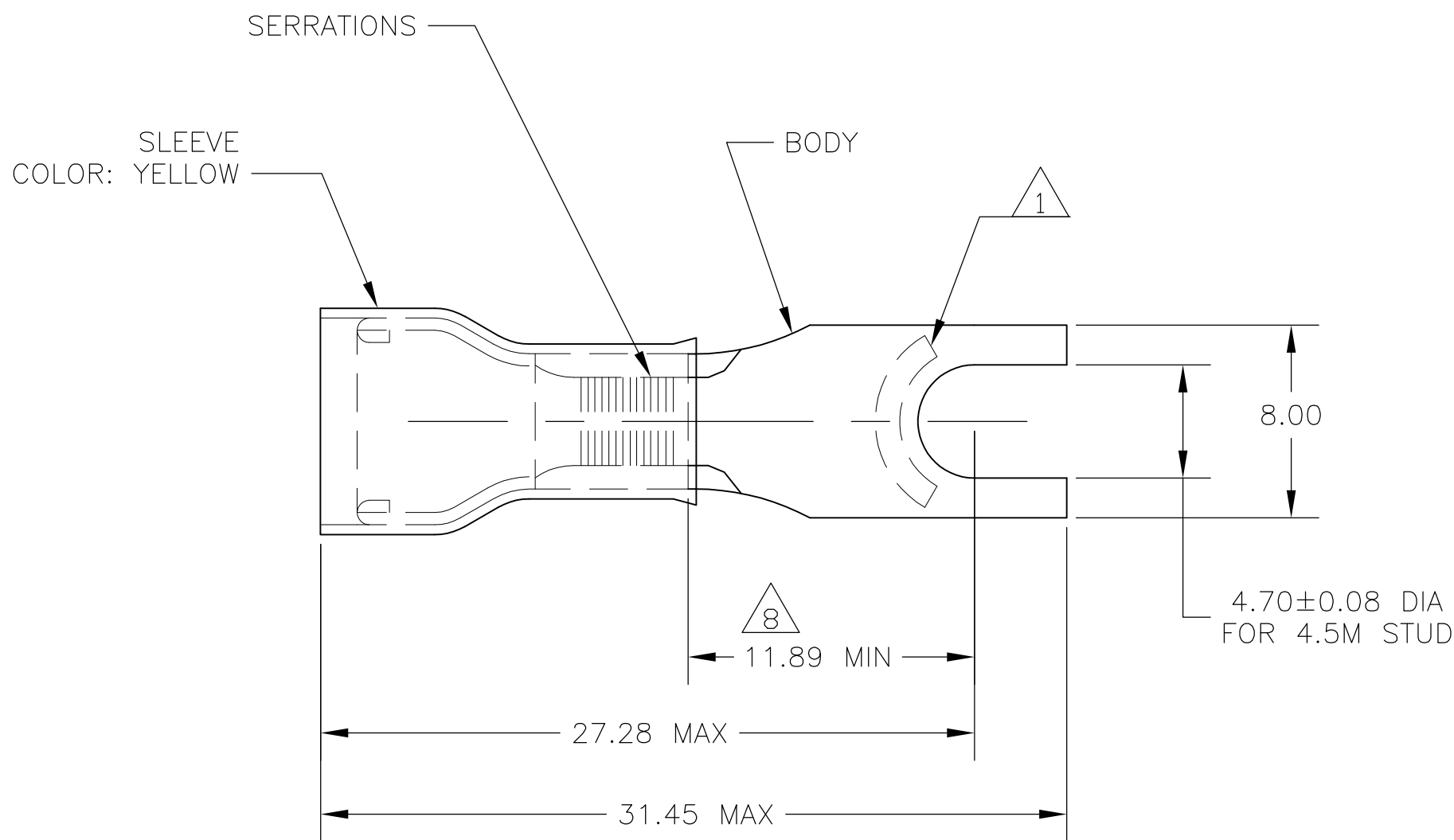

- 1 STAMP "AMP 12-10\*", LOCATION APPROX AS SHOWN.
- 2 WIRE INSULATION DIA 3.8-6.4
- 3 OPERATING TEMPERATURE 90°C MAX
- 4 VOLTAGE RATING 600V MAX
- 5 CMA 2.62-6.64mm<sup>2</sup> [5,180-13,100]
- 6 MATERIAL:  
BODY - COPPER PER ASTM B-152  
INSULATION - PVC
- 7 FINISH:  
BODY - TIN PL PER ASTM B-545  
INSULATION - COLOR-YELLOW
- 8 APPLIES FROM EDGE OF METAL WIRE BARREL TO CENTER OF STUD HOLE.
- 9 MATERIAL THICKNESS IS 1.00±0.05

REEL, ON TAPE	2-165015-1
LOOSE PIECE	165015
PACKAGE TYPE	PART NO

THIS DRAWING IS A CONTROLLED DOCUMENT.		DWN jr_ruth 20FEB06	Tyco Electronics Corporation Harrisburg, PA 17105-3608			
DIMENSIONS: MM <del>INCHES</del>		CHK T MICHIELUTTI 20FEB06				
TOLERANCES UNLESS OTHERWISE SPECIFIED: 0 PLC ± - 1 PLC ± - 2 PLC ± 0.20 3 PLC ± - 4 PLC ± - ANGLES ± 5°		APVD T MICHIELUTTI 20FEB06	NAME TERMINAL SPADE, PIDG, WIRE SIZE 12:10			
MATERIAL -		FINISH -	PRODUCT SPEC -	APPLICATION SPEC -		
		WEIGHT -	SIZE A3	CAGE CODE 00779	DRAWING NO C-165015	RESTRICTED TO -
CUSTOMER DRAWING			SCALE 4:1	SHEET 1 OF 1	REV B	